

Installation Instructions Part No. 311166-755

NOTE: Read the entire instruction manual before starting the installation.

This symbol → indicates a change since the last issue.

SAFETY CONSIDERATIONS

Installing and servicing of heating equipment can be hazardous due to gas and electrical components. Only trained personnel should install or service heating equipment.

Untrained personnel can perform basic maintenance functions such as cleaning coils or cleaning and replacing filters. All other operations should be performed by trained service personnel. When working on heating equipment, observe precautions in the literature, on tags, and on labels attached to the unit.

Follow all safety codes. Wear safety glasses and work gloves. Have a fire extinguisher available.

Recognize safety information. This is the safety-alert symbol . When you see this symbol on the furnace and in instructions or manuals, be alert to the potential for personal injury.

Understand the signal words, DANGER, WARNING, and CAUTION. These words are used with the safety-alert symbol. DANGER identifies the most serious hazards which **will** result in severe personal injury or death. WARNING signifies a hazard which **could** result in personal injury or death. CAUTION is used to identify unsafe practices which **may** result in minor personal injury or product and property damage. NOTE is used to highlight suggestions which **will** result in enhanced installation, reliability, or operation.

WARNING

FIRE, EXPLOSION AND ELECTRICAL SHOCK HAZARD

Failure to follow this warning could result in personal injury, death and/or property damage.

Turn off gas and electrical supplies to unit before beginning any installation or modification. Follow operating instructions on label attached to furnace.

CAUTION

UNIT DAMAGE HAZARD

Failure to follow this caution may result in improper and dangerous operation.

Label all wires prior to disconnection when servicing controls.

INTRODUCTION

→ This instruction manual covers installation of the pressure tube kit Part No. 311166-755 in all gas-fired condensing furnaces.

DESCRIPTION AND USAGE

This pressure tube kit is designed for use when replacement of the factory-installed tubing is required.

→ This kit is for use with models 320AAZ, 321AAZ, 340MAV, 345MAV, 350MAV, 351DAS, 352MAV, 355MAV, 340AAV, 350AAV, 352AAV, 355AAV, 398AAV, 398AAZ, 398BAZ, 399AAZ, 490AAV, 58DX, 58DXA, 58DXC, 58MCA, 58MSA, 58MVP, 58MTA, 58MXA, 58MCB, 58MVB, 58MTB, 58MXB, 58SX, 58SXA, 58SXB, 58SXC, 58VCA, 58VUA, PG9MAA, and PG9MAB Gas-Fired Condensing Furnaces.

This pressure tube kit contains the following items:

Tubing (1 length to be cut to size)	3
Plastic tee	3
Clamps	18
Installation Instructions	1

INSTALLATION

1. Turn off gas and electrical supplies to unit.
2. Remove furnace door.
3. Cut tubing to proper length as required. Refer to appropriate figure for required tubing lengths as shown in Table 1.
4. Install clamps (provided in kit) on ends of new tubes.

NOTE: Pressure tubing in units may be routed slightly different than what is shown in diagrams. Where possible, refer to tubing label on unit.

5. Replace all tubing called out in proper figures.

NOTE: Remove and replace 1 tube at a time. Ensure tubing is routed in same manner as original pressure tubing.

- 6. Place pressure tube assembly behind casing clips (if applicable). Make sure the tubes are not to be kinked or pinched, as this will affect furnace operation.
7. Check pressure tubes to ensure connections are completed and secure.
8. Turn on gas and electrical supplies to unit.
9. Check furnace for proper operation through 2 complete cycles.
10. Reinstall furnace door.

→

Table 1—Reference Figure Usage

MODEL NUMBER	SERIES	REFERENCE FIGURE
320AAZ	All	4
321AAZ	All	5
340AAV	A and later series	7
340MAV	A	6
	B, C, D (prior to 2496A02149 and after 1098A02241), and later series	7
	D (between 2496A02149 and 1098A02241)	8
345MAV	A (through 1098A02241)	8
	A (after 1098A02241) and later series	7
350AAV	A and later series	7
350MAV	A	6
	B, C, D (prior to 2496A02149 and after 1098A02241) and later series	7
	D (2496A02149 through 1098A02241), and later series	8
351DAS	All	10
352AAV	A and later series	11
352MAV	All	11
355AAV	A and later series	9
355MAV	All	9
398AAV	All	1
398AAZ	All	1
398BAZ	All	3
399AAZ	All	2
490AAV	A	6
	B, C, D (prior to 2496A02149 and after 1098A02241), and later series	7
	D (2496A02149 through 1098A02241)	8
58DX	All	2
58DXA	All	2
58DXC	All	2
58MCA	100	6
	100, 120, 130 (prior to 2496A02149 and after 1098A02241), and later series	7
	130 (2496A02149 through 1098A02241)	8
58MCB	100 and later series	7
58MSA	100 (through 1098A02241)	8
	100 (after 1098A02241), and later series	7
58MTA	All	11
58MTB	100 and later series	11
58MVB	100 and later series	9
58MVP	All	9
58MXA	100	6
	110, 120, 130 (prior to 2496A02149 and after 1098A02241) and later series	7
	130 (2496A02149 through 1098A02241)	8
58MXB	100 and later series	7
58SX	All	1
58SXA	All	1
58SXB	All	3
58SXC	All	1
58VCA	All	5
58VUA	All	4
PG9MAA	A (through 1098A02241)	8
	A after (1098A02241) and later series	7
PG9MAB	A and later series	7

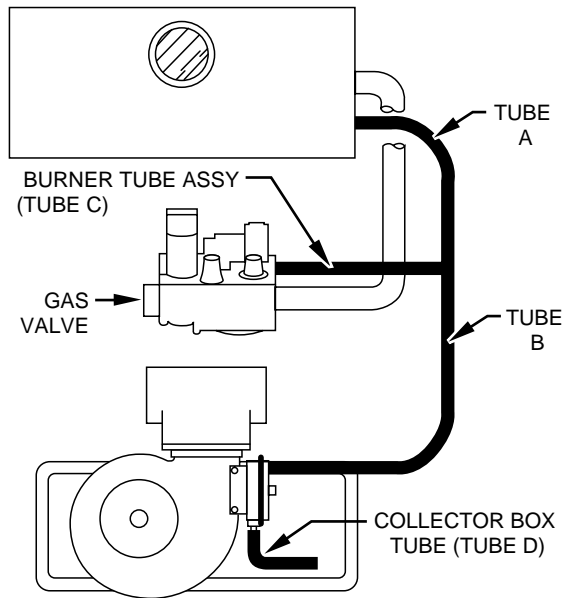

A92078

Maximum Pressure Tube Length*

UNIT SIZE	TUBE LENGTH (IN.)			
	A	B	C	D
040 & 060	11	13	9	9
080	11	13	7-1/2	9
100	11	15	7-1/2	9
120	11	16	7-1/2	9

* Shorter lengths may be required to avoid kinking tubing. This will depend upon the gas valve and pressure switch used. Refer to existing tubing lengths, if possible.

Fig. 1—Pressure Tube Connection Diagram for Models 398AAV, 398AAZ, 58SX, 58SXA, and 58SXC Furnaces

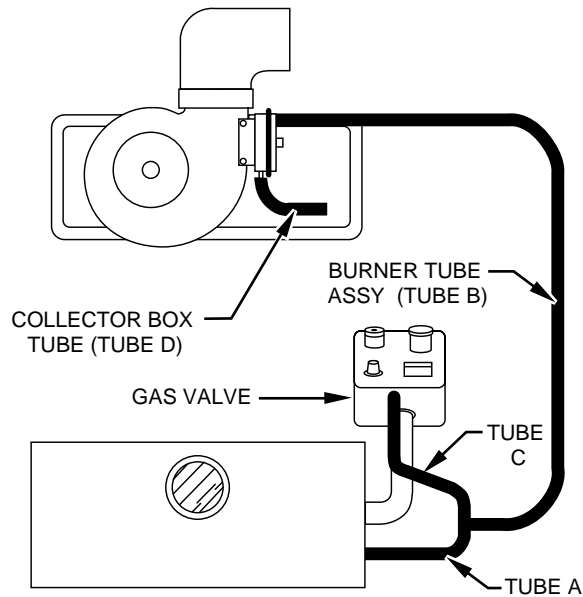

A92079

Maximum Pressure Tube Length*

UNIT SIZE	TUBE LENGTH (IN.)			
	A	B	C	D
All	6	26	6	6

* Shorter lengths may be required to avoid kinking tubing. This will depend upon the gas valve and the pressure switch used. Refer to existing tubing lengths, if possible.

Fig. 2—Pressure Tube Connection Diagram for Models 399AAZ, 58DX, 58DXA, and 58DXC Furnaces

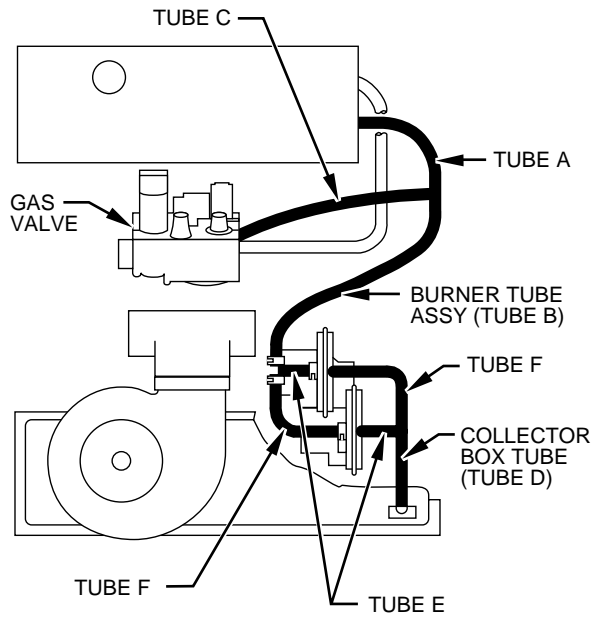

A92080

Maximum Pressure Tube Length*

UNIT SIZE	TUBE LENGTH (IN.)					
	A	B	C	D	E	F
All	5	12	9	3-1/2	1-3/8	4-1/2

* Shorter lengths may be required to avoid kinking tubing. This will depend upon the gas valve and the pressure switch used. Refer to existing tubing lengths, if possible.

Fig. 3—Pressure Tube Connection Diagram for Models 398BAZ and 58SXB Furnaces

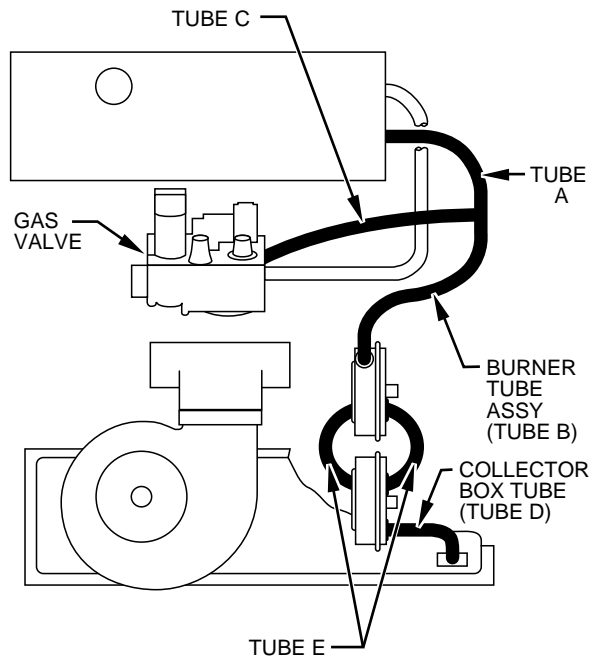

A92081

Maximum Pressure Tube Length*

UNIT SIZE	TUBE LENGTH (IN.)				
	A	B	C	D	E
All	5	12	9	5	4

* Shorter lengths may be required to avoid kinking tubing. This will depend upon the gas valve and the pressure switch used. Refer to existing tubing lengths, if possible.

Fig. 4—Pressure Tube Connection Diagram for Models 320AAZ and 58VUA Furnaces

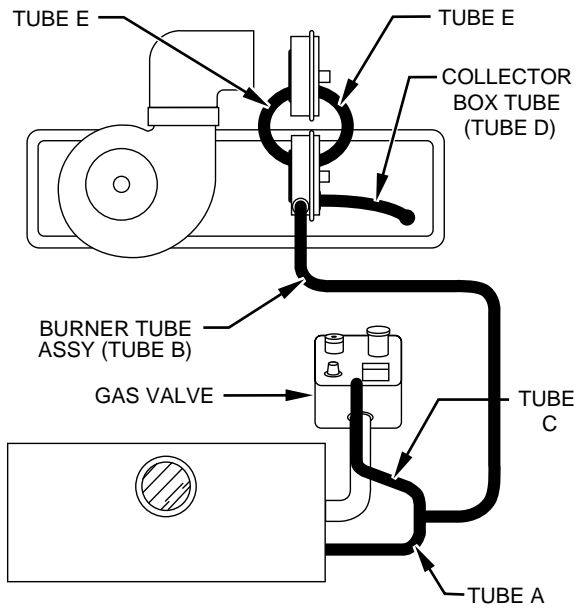

A92082

Maximum Pressure Tube Length*

UNIT SIZE	TUBE LENGTH (IN.)				
	A	B	C	D	E
All	6	26	6	4	4

* Shorter lengths may be required to avoid kinking tubing. This will depend upon the gas valve and the pressure switch used. Refer to existing tubing lengths, if possible.

Fig. 5—Pressure Tube Connection Diagram for Models 321AAZ and 58VCA Furnaces

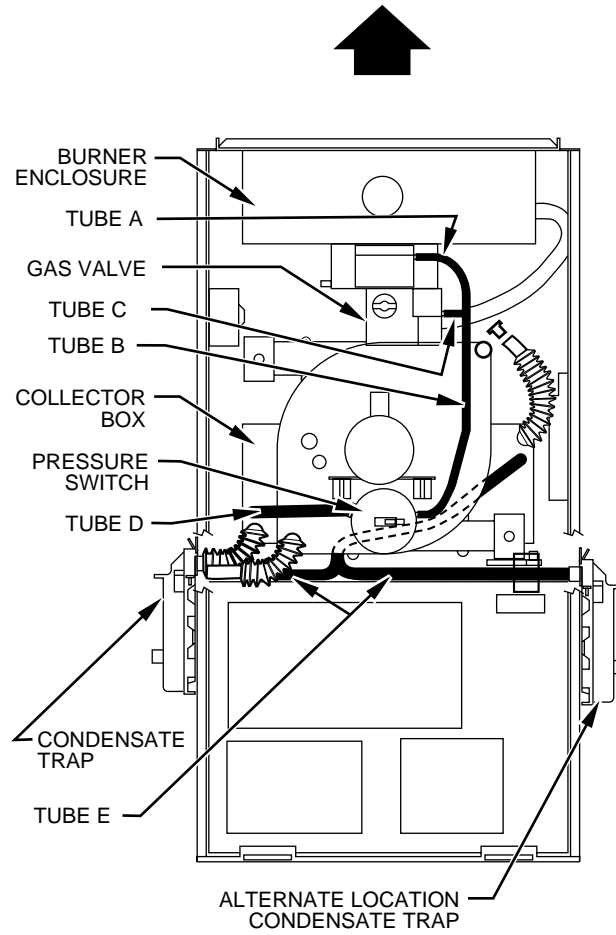

A94267

Maximum Pressure Tube Length*

UNIT SIZE	TUBE LENGTH (IN.)				
	A	B	C	D	E†
040	8	13	2	8-3/4	18-1/2
060	8	13	2	8-3/4	18-1/2
080	8	13	2	8-3/4	20-1/2
100	8	13	2	8-3/4	20-1/2
120	8	13	2	8-3/4	20-1/2

* Shorter lengths may be required to avoid kinking tubing. This will depend upon the gas valve and the pressure switch used. Refer to existing tubing lengths, if possible.

† Length will vary depending on location of furnace condensate trap.

Fig. 6—Pressure Tube Connection Diagram for Series A Models of 340MAV, 350MAV, and 490AAV and Series 100 Models of 58MCA and 58MXA 40-in. Tall Multipoise Furnaces (Upflow Orientation Shown)

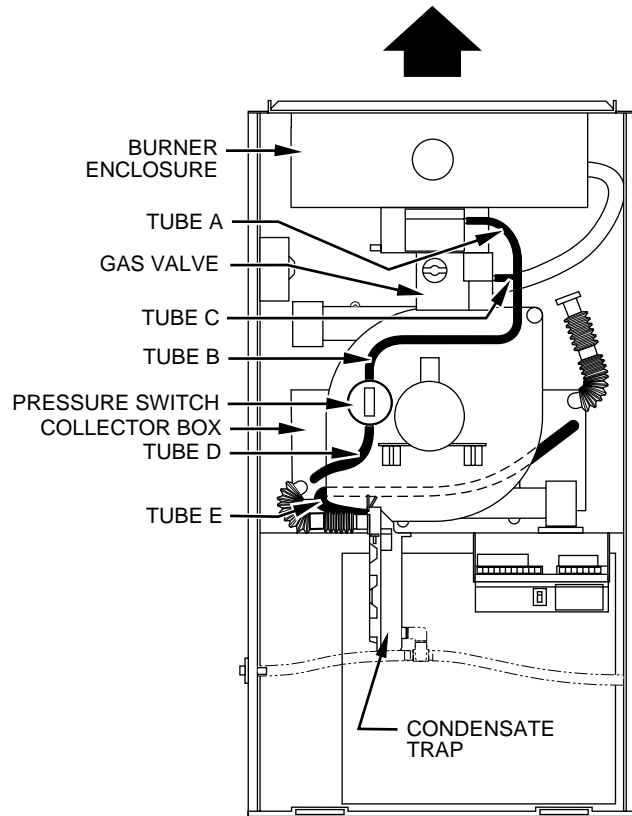

A94268

Maximum Pressure Tube Length*

UNIT SIZE	TUBE LENGTH (IN.)				
	A	B	C	D	E†
040	5	10	1-1/2	9-1/4	24
060	5	10	1-1/2	9-1/4	24
080	6	11-1/2	1-1/2	9-1/4	24
100	6	11-1/2	1-1/2	9-1/4	24
120	8	11-1/2	1-1/2	9-1/4	24

* Shorter lengths may be required to avoid kinking tubing. This will depend upon the gas valve and pressure switch used. Refer to existing tubing lengths, if possible.

† Length will vary depending on location of furnace condensate trap.

Fig. 7—Pressure Tube Connection Diagram in 40 in. Tall multipoise Furnace (Upflow Orientation Shown) for Models 340MAV, 350MAV, and 490AAV Series B, C, D (prior to 2496A02149 and after 1098A02241) and later series; Models 58MCA and 58MXA Series 110, 120, 130 (prior to 2496A02149 and after 1098A02241) and later series; Model 345MAV Series A (after 1098A02241) and later series; Model 58MSA Series 100 (after 1098A02241) and later series; Model PG9MAA Series A (after 1098A02241) and later series; Model PG9MAB Series A and later series; Models 340AAV and 350AAV Series A and later series; Models 58MCB and 58MXB Series 100 and later series

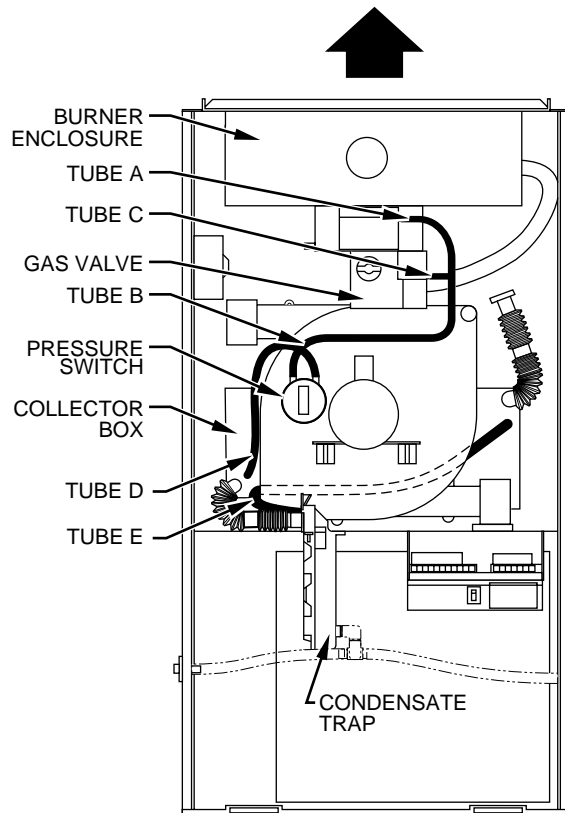

A96252

UNIT SIZE	TUBE LENGTH (IN.)				
	A	B	C	D	E†
040	5	10	1-1/2	15-1/4	22
060	5	10	1-1/2	15-1/4	22
080	6	11-1/2	1-1/2	15-1/4	22
100	6	11-1/2	1-1/2	15-1/4	22
120	8	11-1/2	1-1/2	15-1/4	22
140	8	11-1/2	1-1/2	15-1/4	22

* Shorter lengths may be required to avoid kinking tubing. This will depend upon the gas valve and pressure switch used. Refer to existing tubing lengths, if possible.

† Length will vary depending on location of furnace condensate trap.

Fig. 8—Pressure Tube Connection Diagram (Upflow Orientation Shown) for Models 340MAV, 345MAV, 350MAV, 58MCA, 58MSA, 58MXA, PG9MAA and 490AAV (between 2496A02149 and 1098A02241)

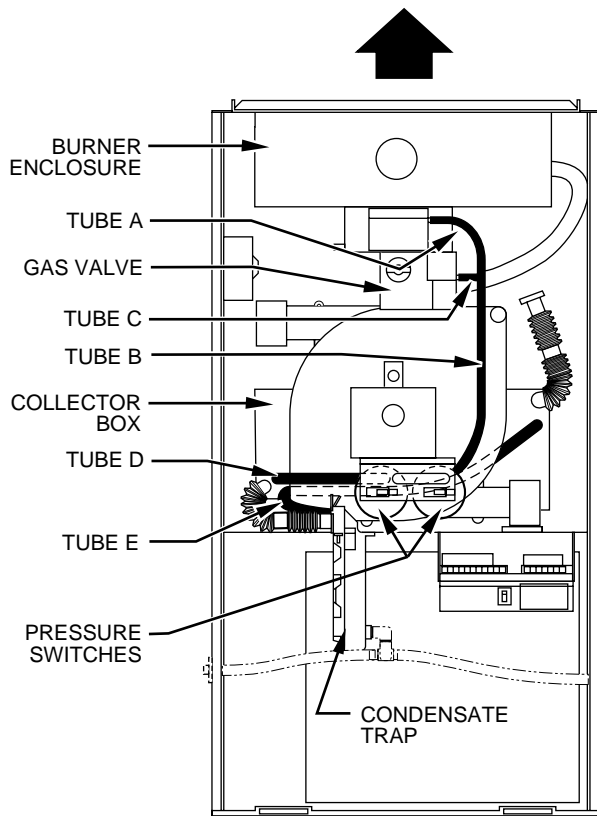

A94269

Maximum Pressure Tube Length*

UNIT SIZE	TUBE LENGTH (IN.)				
	A	B	C	D	E†
040	6-1/2	13-1/2	3	10-1/2	24
060	6-1/2	13-1/2	3	10-1/2	24
080	6-1/2	13-1/2	3	10-1/2	24
100	6-1/2	13-1/2	3	10-1/2	24
120	8	13-1/2	1-1/2	10-1/2	24

* Shorter lengths may be required to avoid kinking tubing. This will depend upon the gas valve and pressure switch used. Refer to existing tubing lengths, if possible.

† Length will vary depending on location of furnace condensate trap.

Fig. 9—Pressure Tube Connection Diagram in a 40-in. Tall Multipoise Furnace (Upflow Orientation Shown) for Models 355MAV, 355AAV, 58MVP, and 58MVB

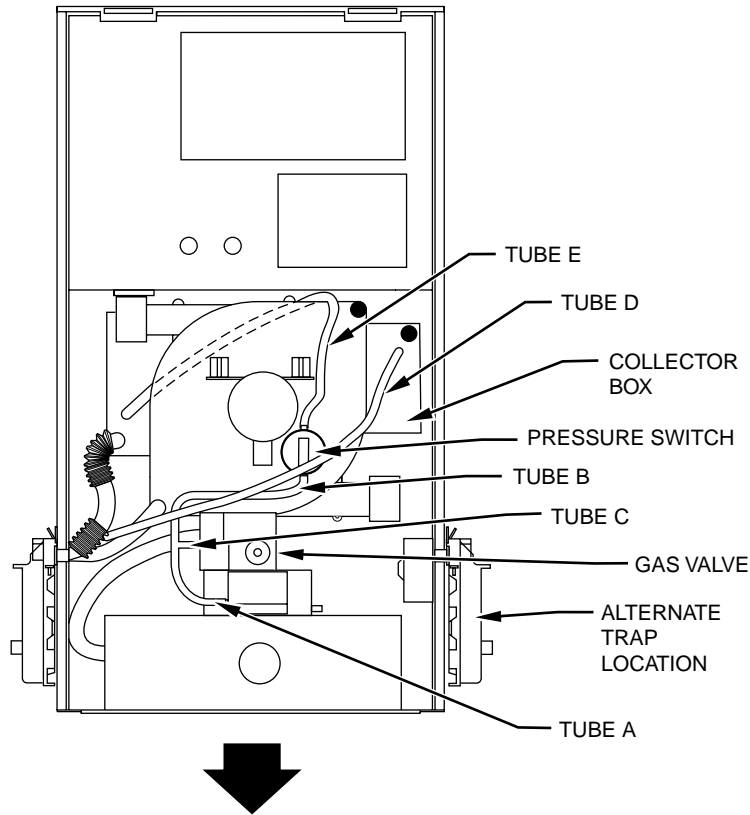

A99058

Maximum Pressure Tube Length*

UNIT SIZE	TUBE LENGTH (IN.)				
	A	B	C	D†	E
080	6	11-1/2	1-1/2	26	24

* Shorter lengths may be required to avoid kinking tubing. This will depend upon the gas valve and pressure switch used. Refer to existing tubing lengths, if possible.

† Length will vary depending on location of furnace condensate trap.

Fig. 10—Pressure Tube Connection Diagram for Model 351DAS 40-in. Tall Downflow Furnaces

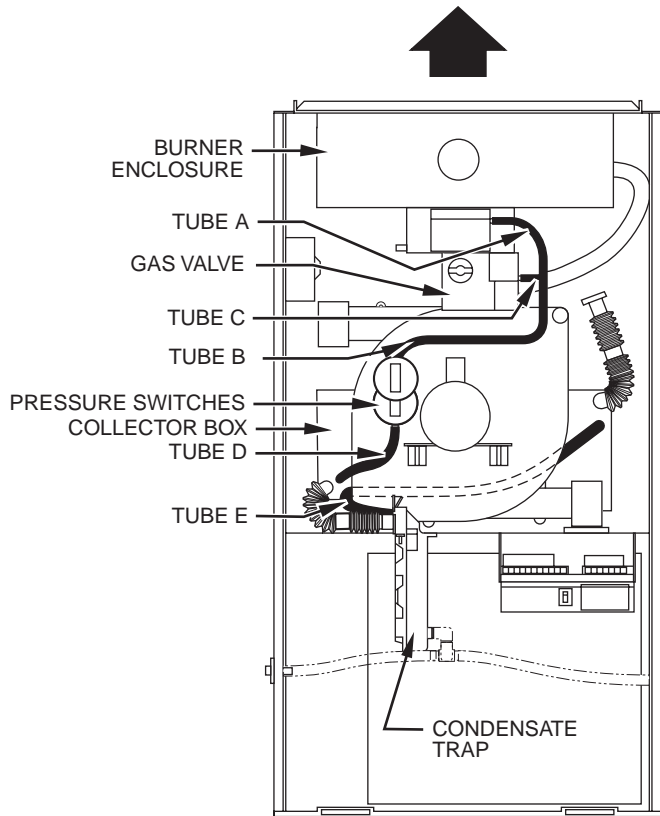

A01079

Maximum Pressure Tube Length*

UNIT SIZE	TUBE LENGTH (IN.)				
	A	B	C	D	E†
060	5	10	1-1/2	6	24
080	6	11-1/2	1-1/2	6	24
100	6	11-1/2	1-1/2	6	24
120	8	11-1/2	1-1/2	6	24

* Shorter lengths may be required to avoid kinking tubing. this will depend upon the gas valve and pressure switch used. Refer to existing tubing lengths, if possible.

† Length will vary depending on location of furnace condensate trap.

Fig. 11—Pressure Tube Connection Diagram in a 40in. Tall Multipoise Furnace (Upflow Orientation Shown) for Models 352MAV, 352AAV, 58MTA, and 58MTB

Manufacturer reserves the right to discontinue, or change at any time, specifications or designs without notice and without incurring obligations.